



Key Technologies for Mitsubishi LNG Carrier - Now and in the Future -

HIROYUKI OHIRA*1

SHOICHI MATSUMOTO*1

SAI HIRAMATSU*1

YOSHIKAZU FUJINO*2

The global demand for energy is increasing. Among the energies available, LNG (liquefied natural gas) is drawing increasing attention for its relatively low emission of CO₂ at combustion, compared to petroleum and coal. Mitsubishi Heavy Industries, Ltd. (MHI) started developing LNG carriers in the 1970s. Since delivering its first LNG carrier in 1983, MHI has developed low BOR (boil-off rate) techniques, sophisticated automation systems, re-liquefaction plants, winterization systems, and other advanced technologies for application to actual ships. MHI is still building highly reliable and economical LNG carriers. The company is now constructing advanced LNG carriers with two kinds of tank system, including a spherical tank type and membrane type. The knowledge collected based on MHI's actual achievements is being used to develop next-generation technologies for the construction of large ships, winterized ships, and highly efficient steam turbine ships.

1. Introduction

MHI began developing LNG carriers in the 1970s. It delivered its first ship of the spherical tank type, the Banshumaru, in 1983. Since then, MHI has built 42 LNG carriers (including those now being built). The diverse engineering developments incorporated into the designs for these ships have led to the establishment of highly safe and reliable LNG carrier technologies. In this article we look back on these engineering developments and describe future developments in consideration of the trends in business negotiations expected in the future.

2. MHI's track record in building of LNG carriers

In this section we outline the LNG carriers that MHI has built.

Methane, the main component of LNG (critical temperature of -82°C), cannot be liquefied through pressurization

at normal temperature. In general, methane is liquefied at -162°C at atmospheric pressure and then transported. As vessels that carry such low temperature cargoes, LNG carriers must be built with inboard tanks with extremely low design temperatures. To meet this requirement, MHI adopted a spherical tank type made of aluminum alloy for its first LNG carrier, the Banshumaru (**Fig. 1**) (delivered in 1983).

In 1989, MHI delivered an NWS (North West Shelf, West Australia) project vessel (**Fig. 2**), a second-generation LNG carrier. This vessel is designed with specifications for a 4-tank vessel, a low BOR (boil-off rate: the rate at which the gas generated from the tank evaporates), a FORCING VAPORIZER, and a centralized monitoring and control system for the equipment in the engine portion and cargo portion. This marked a clear departure from the specifications for previous LNG vessels and set the standard for subsequent LNG carriers.



Fig. 1 Banshumaru



Fig. 2 Northwest Sandering

*1 Nagasaki Shipyard & Machinery Works

*2 Shipbuilding & Ocean Development Headquarters

MHI and collaborators became the first to load a BOG (boil-off gas) re-liquefaction plant onto an LNG vessel in 2000, for the construction of the LNG Jamal (Fig. 3). The project was conducted jointly with Osaka Gas Co., Ltd., NYK Line, and Chiyoda Corporation.



Fig. 3 LNG Jamal

Before the era, MHI had developed and built LNG carriers of the spherical tank type. Later, in August 2002, MHI delivered the PUTERI INTAN SATU (the photo on the top page), a 137,000 m³ type LNG carrier with a Gaz Transport Containment System. This made MHI the world's first shipbuilding yard to develop and build LNG carriers of both the spherical tank type and membrane type. The membrane type is a type in which the hull incorporates an insulation structure on the inside and an internal covering with membranes (thin films made of metal). Compared with independent tank types such as the spherical tank type, the membrane type can be built with fewer metal materials for low temperatures (Fig. 4). The cargo loads, however, also work on the heat-insulating materials, and thus they

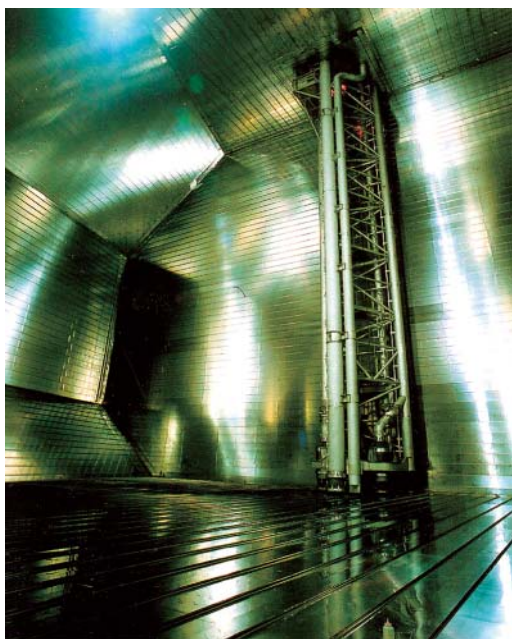

Fig. 4 Membrane ship cargo tank

necessitate structural members for complicated and diverse insulation. To build these members efficiently, MHI developed an automatic welding machine with enhanced welding reliability. It also developed and applied LOGIQ, a process and quality control system capable of controlling the approximately 700,000 members constituting the insulation and membrane structure.

MHI delivered two SNOHVIT project ships in 2006, and this year it is constructing SAKHALIN project ships. As vessels to navigate extremely cold districts, the SNOHVIT and SAKHALIN ships are designed to withstand extremely low outside air temperatures (SNOHVIT project ships, -18°C; SAKHALIN project ships, -25°C), to melt ice, and to prevent freeze-up (Fig. 5). The SAKHALIN project ships are also built with systems to comply with the Finnish-Swedish Ice Class Rule 1B for the assurance of reliable operation at the port of Prigorodnoye, a base for shipment, during icy winter months. The SNOHVIT and SAKHALIN project ships also adopt long-life hull fatigue designs to ensure that the hull structures can withstand repeated fatigue loads over a long period. MHI has developed advanced analysis technologies for analysis of structure, fatigue, etc., and has put to practical use its own fatigue analysis method, DISAM (DIScrete Analysis Method). These analysis technologies are used for the fatigue design.



Fig. 5 External appearance of accommodation space of SNOHVIT project ship

3. Next-generation LNG carriers

So far we have looked at the history of the LNG carriers constructed by MHI in earlier years. MHI has always taken the initiative in building LNG carriers with state-of-the-art technologies while responding to customer needs. In business negotiations nowadays, clients frequently request larger cargo capacity, winterization systems more robust than those adopted for the SNOHVIT and SAKHALIN project ships, and energy savings in main engine plants. Another article in this Technical Review describes winterization and the UST (ultra steam turbine) in detail to exemplify energy saving in the main engine plants. In this article we outline approaches to ship enlargement, winterization, and UST more generally.

3.1 Ship enlargement

As vessels transporting LNG for Japan's domestic market, those in the 150,000 m³ class have the largest hull forms at present. MHI is developing larger hull forms for Japan's domestic market to ensure consistency with major terminals in Japan and respond to the opinions voiced by customers. Customers impose restrictions on the draft, overall length, and depth in order to ensure consistency with domestic terminals in Japan. With the restrictions imposed on the draft and overall length, the hull form needs to be enlarged in order to ensure the largest tank capacity. The hull form also needs to be designed with a thinner body, to ensure that the vessel can travel at the required speed of 19.5 kt. To meet these contradictory requirements, the tank capacity is set at 177,000 m³ as the optimum point, and the hull form is made to include the following principal dimensions (Table 1). The depth is set at 28 meters in consideration of the consistency with a gangway on the land side and reduction in the hull weight.

Table 1 principal dimensions for 177 000 m³ type

Loa (overall length)	(m)	300.0
Lpp (length between perpendiculars)	(m)	287.0
B (breadth)	(m)	51.9
D (depth)	(m)	28.0
d (draft)	(m)	11.5
Vs (service speed)	(kt)	19.5
MCR (maximum continuous output)	(kW)	29 900
FOC (rate of fuel consumption)	(t/day)	157.3
Cargo capacity (cargo tank capacity)	(m ³)	177 000
Number of cargo tanks		4

The worldwide trend now is to make hull forms larger. Korean shipbuilders are constructing membrane vessels exceeding 200,000 m³, such as the Q-flex and Q-max. Yet when constructing membrane vessels of over 180,000 m³, the vessel must be equipped with five tanks to avoid the increase of sloshing load caused by cargo liquid oscillation. With the stronger spherical tanks, however, a four-tank vessel can be enlarged. In addition to having the capability to build four-tank 200,000 m³ vessels of spherical tank type, MHI is studying the FST (flex spherical tank) type (Fig. 6) as a method of increasing the tank capacity further.

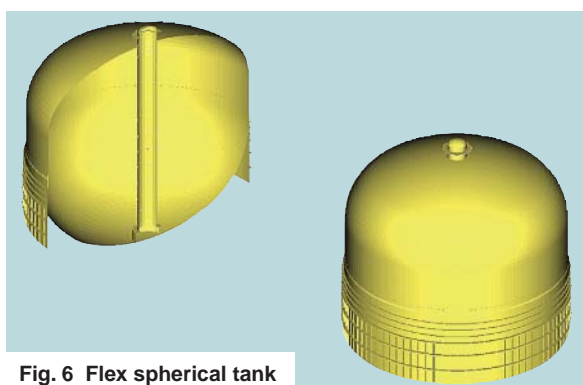

Fig. 6 Flex spherical tank

The FST type makes good use of the features of the spherical tank type, and changes the curvatures of the northern hemisphere and southern hemisphere to secure as high of a storage capacity as possible in a tank with the same tank diameter as the spherical tank. MHI has already obtained an AIP (approval in principle) from Nippon Kaiji Kyokai and Lloyd's Register. By applying the FST to a 200,000 m³ four-tank vessel, it will be possible to increase the tank capacity to 230,000 m³. When the curvature is changed, on the other hand, the tank becomes heavier than the spherical tank and a new hull form must be developed to accommodate the increased weight.

There are no special problems entailed in the enlargement of membrane vessels. With the increase in the amount of material of the cargo containment, however, improvements in productivity are required.

3.2 Winterization

The regulation of the classification society includes a stipulation for an ice-resistant construction. Ice-resistance requirements are clearly described for the hull construction, main engine output, towing apparatus, rudder, steering gear, propeller and shaft shape. This regulation sets down minimum specifications for an ice-resistant construction to ensure the safe operation of a ship (as its name suggests) through waters with a covering of ice on the sea surface. The other general outfittings are subject to practically no requirements under the regulation. Det Norske Veritas applies DEICE as a notation for ships for cold districts. This guidance, however, is intended mainly for small ships sailing in the Baltic Sea. Application of DEICE to large LNG carriers is therefore difficult. Classification societies are studying regulations for winterization applicable to large ships by referring to the regulations for ships sailing in the Arctic and Antarctic. Yet the specification requirements in the regulations for winterization now being studied seem excessive compared with those for ships currently in service in cold districts. Indeed, some of the specification requirements cannot be considered truly rational. Customers and shipbuilding yards are discussing ways to design and build LNG carriers with reasonable specifications and high economic efficiency in operation, with approval by the classification societies and regulatory bodies.

Various kinds of winterization are conceivable, depending on how the customers operate, the environment (e.g., temperature and marine phenomena) in which the winterization is to be applied, and the proficiency of crew members. MHI has already designed and constructed SNOHVIT project ships with limited winterization provisions for service as LNG carriers for cold districts, and SAKHALIN project ships with ice-resistant constructions for sailing in ice-bound seas. Based on these design and construction experiences, MHI is now researching and developing technologies to prepare for the anticipated requirements of the coming generations of LNG carriers to be built for much severer environments in cold districts.

3.3 UST (Ultra Steam Turbine)

Skyrocketing crude oil prices in recent years have drastically accelerated the demand for energy-saving technologies for propulsion plants. In the world of LNG carriers, electric propulsion ships (DFE ships) using medium-speed diesel engines with gas-firing capability and two-cycle low-speed diesel main engine vessels (DRL ships) have been gaining power in place of conventional steam turbines. To compete with these highly efficient propulsion engines, MHI has developed a UST plant in which highly reliable conventional steam turbines operate at greatly improved efficiency. This plant is designed to improve the efficiency by enhancing the steam conditions from 6 MPa x 515°C (standard level in the past) to 10 MPa x 560°C, and leading the steam which is reheated by the reheater to a intermediate-pressure turbine newly provided. To enhance the pressure and temperature conditions in this development, MHI made maximum use of the technologies it has accumulated in the manufacture of land plants. The turbine incorporates a land reheat turbine design technology and an optimized casing structure enjoined by marine turbines with a high starting and stopping frequency. The reheat boiler, meanwhile, is compact, equipped with a reheat furnace on the exhaust gas outlet side, and designed to minimize risk. The reliability of the entire plant has been enhanced through furnace gas flow analysis simulations, cold model tests, plant simulations in ship operation mode and so on.

In all of the work operations mentioned above, MHI has been able to obtain the expected achievements under the company-wide system with the Technical Headquarters, machinery division, and shipbuilding division in cooperation with one another. This plant is compact enough to be placed in the engine room of a conventional ship. It is designed simply, with superior operability and maintainability (Fig. 7). The UST reduces fuel consumption by about 15% compared with the conventional steam turbines and will be able to compete well with DFE ships and DRL ships in consideration of maintenance.

3.4 Others

This article has outlined technologies to be considered in future business negotiations for ship enlargement, winterization, and UST. Aside from these technologies, specifications for ships are now being reexamined from the viewpoint of modular design. It is most important to obtain a customer's satisfaction in a business negotiation by applying all of the absolutely essential individual technologies. Yet even when individual technologies are applied, the design of an entire ship will not be overturned funda-

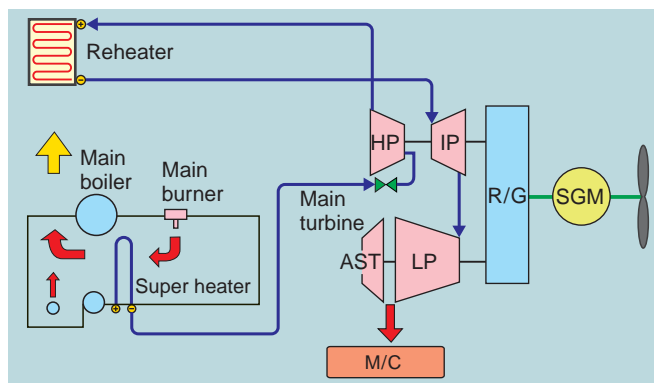

Fig. 7 Ultra Steam Turbine

mentally. The first steps are to complete a basic arrangement that many customers will accept, and then to divide the sections into those that can be changed and those that cannot. For the portions that can be changed, several options should be made available. This approach makes it possible to set specifications to satisfy the customer while omitting the design of common parts. If there are many common parts, it will be easy to apply feedback from ships that have already been constructed and those that have already been delivered. Thus, the next ships to be built will be finished more completely and more satisfying to the customer. This will be required, along with the development of individual technologies, in future LNG carrier development.

4. Conclusion

MHI has constructed many LNG carriers and has developed various technologies for low BOR, forced evaporation units, automation systems, BOG re-liquefaction plants, and winterization with top priority on safety, reliability, and high economic efficiency. Customers will henceforth be requesting larger ships, ships with improved energy-saving performance, and robustly winterized ships. All will be required to operate with high economic efficiency. MHI will need to develop high-technology LNG carriers in line with these customer needs and its own high standards of safety, reliability, and high economic efficiency.

References

- (1) Ono, M. et al., Technical View of LNG Carriers and LPG Carriers, Mitsubishi Heavy Industries Technical Review Vol. 21 No. 3 (1984)
- (2) Takakura, O. et al., Design Characteristics for a New Generation of LNG Carriers, Mitsubishi Heavy Industries Technical Review Vol. 29 No. 1 (1992)
- (3) Yuasa, K. et al., Key Technologies of Mitsubishi LNG Carriers - Present and Future -, Mitsubishi Heavy Industries Technical Review Vol. 38 No. 2 (2001)



Hiroyuki Ohira



Shoichi Matsumoto



Sai Hiramatsu



Yoshikazu Fujino