



Progressing Steadily, Development of High- Efficiency SOFC Combined Cycle System

TADASHI GENGO*1
NAGAO HISATOME*2
YOSHIMASA ANDO*1

YOSHINORI KOBAYASHI*1
TATSUO KABATA*2
KENICHIRO KOSAKA*3

1. Introduction

The SOFC (solid oxide fuel cell) is a fuel cell which operates at temperatures between 900 and 1,000°C. Various kinds of fuel, including coal, can be used for SOFCs. Regardless of its size, because it can yield higher power efficiency in comparison with a conventional thermal engine, even when used as a single unit, and can operate at high temperature, combined cycle power generation with a gas turbine is made possible. Because further improvements in efficiency are expected, the SOFC is attracting attention as a future high-efficiency thermal power system.

Since the start of development activity in 1984, Mitsubishi Heavy Industries, Ltd. (MHI) has worked on the development of cell materials, cell structure, production technologies, and cell modules. As the tubular type SOFC developed by MHI has a robust structure, it is suitable for use in systems involving dynamic fluctuations such as the gas turbine combined cycle system. As the first step toward realizing a combined cycle system using the SOFC and the gas turbines based on these special characteristics, MHI contracted a project with the New Energy and Industrial Technology Development Organization (NEDO) in fiscal 2004 concerning the "development of a tubular type SOFC high-efficiency combined cycle system," and successfully conducted development and verification of its elements and control technology until fiscal 2005. Through fiscal 2006, we have been working on preparing the construction of a 200 kW class combined cycle system by integrating the tubular type SOFC and the micro gas turbine (MGT).

2. Characteristics of SOFC combined cycle system

Figure 1 is a diagram of the SOFC-MGT combined cycle system. The SOFC is located upstream of the gas turbine combustor. City gas is first supplied as fuel to the SOFC. After the chemical energy of the fuel is converted directly into electricity, the residual fuel is sent to the gas turbine. Thus all of the fuel can be used to produce electricity. Meanwhile, the air is compressed

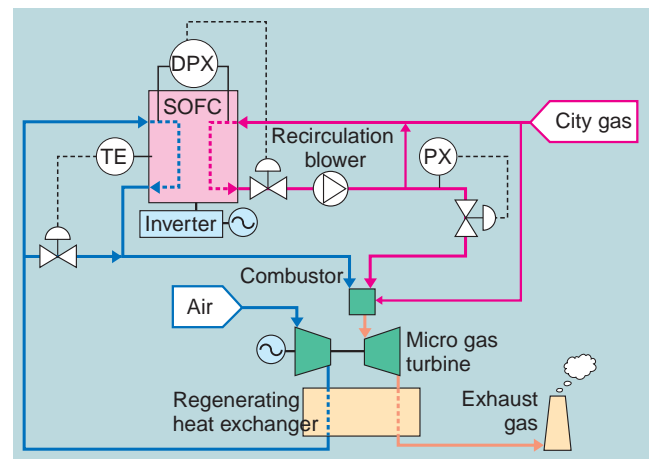

Fig. 1 SOFC micro gas turbine combined cycle system
The world's largest pressurized combined cycle system realized through combination with micro gas turbine.

by the gas turbine compressor and supplied to the SOFC, and after being used as the oxidizing agent of the pressurized SOFC is sent to the gas turbine together with high-temperature exhaust heat. In the gas turbine, both the sensible heat and pressure of the high-temperature pressurized air, as a part of the heat source, are also converted into electricity by the generator, contributing to the high power-generation efficiency of the total system.

The tubular type SOFC has a system configuration in which the exhaust fuel is not burnt inside the SOFC module, but exhaust fuel and exhaust air are extracted separately. When compared with a system where combustion takes place inside the module, this system reduces the temperatures of the exhaust fuel and exhaust air at the SOFC module outlet. Therefore it sends the fuel to the gas turbine combustor while maintaining a low pipe temperature between the SOFC and the gas turbine, where combustion takes place, to raise the turbine inlet temperature, enabling the gas turbine to be operated at high efficiency with a high output. In large-capacity combined cycle systems, as the high-temperature piping imposes design restrictions, it is advantageous to extract exhaust fuel and exhaust air separately.

*1 Power Systems Headquarters

*2 Nagasaki Shipyard & Machinery Works

*3 Nagasaki Research & Development Center, Technical Headquarters



Fig. 2 High-powered cell tube Cell tube 1500 mm long and 28 mm diameter

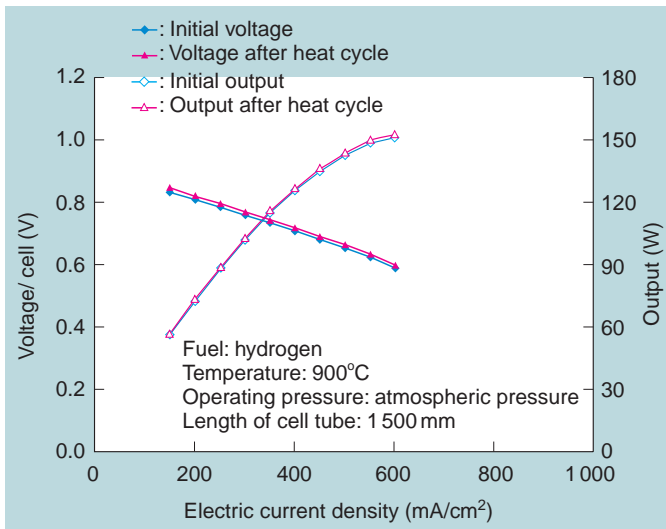

Fig. 3 Current/voltage characteristics of high-powered cell tube
Verification of maximum rated output of 151 W by using high-powered cell tube

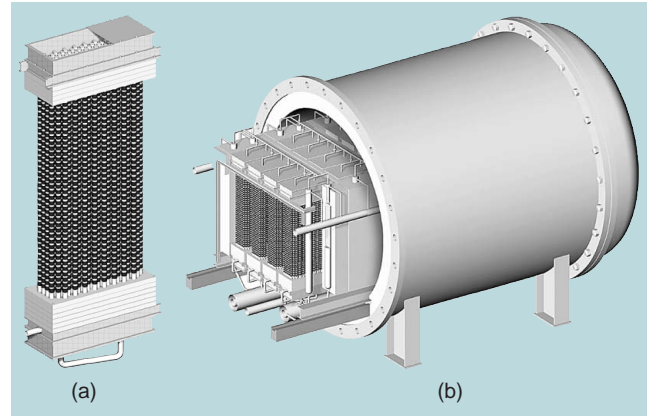

Fig. 4 Structure of (a) cartridge and (b) pressurized module
Cartridge type superior in reliability and extendability is adopted as the module.

3. Progress in development of tubular type SOFC high-efficiency combined cycle system

3.1 Technology of increasing power of cell tube

The cell tubes were improved to withstand the increased power of the 200 kW class combined cycle system. With the aim of improving the cell tube performance, the resistance factor was extracted from a numerical simulation, based on which a cell tube of the size of an actual unit (1,500 mm in length x 28 mm in diameter) was developed by incorporating measures such as (1) improving the gas diffusivity, (2) reducing the contact resistance of the air electrode/electrolyte interface through introducing a mixed electro-conductivity intermediate layer, and (3) reducing the axial electric resistance of the air electrode, and a maximum rating output of 151 W was confirmed. **Figure 2** shows an external view of the tubular type cell and **Figure 3** shows the power generation characteristics. No deterioration in performance or heat cycle performance was observed after heat cycle testing.

3.2 Operation technology of pressurized SOFC module

The cartridge is composed of an aggregation of 104 cell tubes, serving as the minimum unit to supply fuel and air and to collect the current. Four cartridges in alignment make up a sub-module. All modules are placed inside the pressure vessel to operate under pressure. Because of the module configuration arranges each module in the axial direction, the unit capacity can be easily increased. **Figure 4** shows the structures of the cartridge and the module.

In 2005, a 40 kW class module was built and operated, and the output of 35.6 kW, the largest ever obtained in Japan, was confirmed under pressure. **Figure 5** shows the result of the operation test. The objective of this operation test was to check the control characteristics in combined operation with the micro gas turbine, in which a trip test by exposing the SOFC to the most severe conditions (pressure and temperature fluctuations) in the transitional state was conducted. It was confirmed that fluctuations in pressure and temperature right after tripping could be maintained within tolerance and that there was no drop in power after tripping.

3.3 Low-calorific fuel firing micro-gas-turbine

For the SOFC combined cycle system gas turbine, technology was developed to stably burn low-calorific fuels after most of the chemical energy had been consumed in the SOFC. The low-calorific gas combustion technology for blast furnace gas, developed by MHI for its industrial gas turbines, was used in the micro gas turbine combustion unit for the design and manufacture of a low-calorific gas combustion unit for SOFC combined cycle system.

In 2005 the developed combustion unit, after undergoing single-unit combustion testing, was subject to running tests by being mounted on a micro gas turbine (**Fig. 6**). Operation was started using city gas, which was subsequently shifted to simulated low-calorific SOFC exhaust fuel gas (2.6 MJ/m³N-LHV). It was confirmed from the tests that there were no fluctuations in the revolution of the micro gas turbine even during the fuel shifting period and that stable operation is assured with low-calorific fuels.

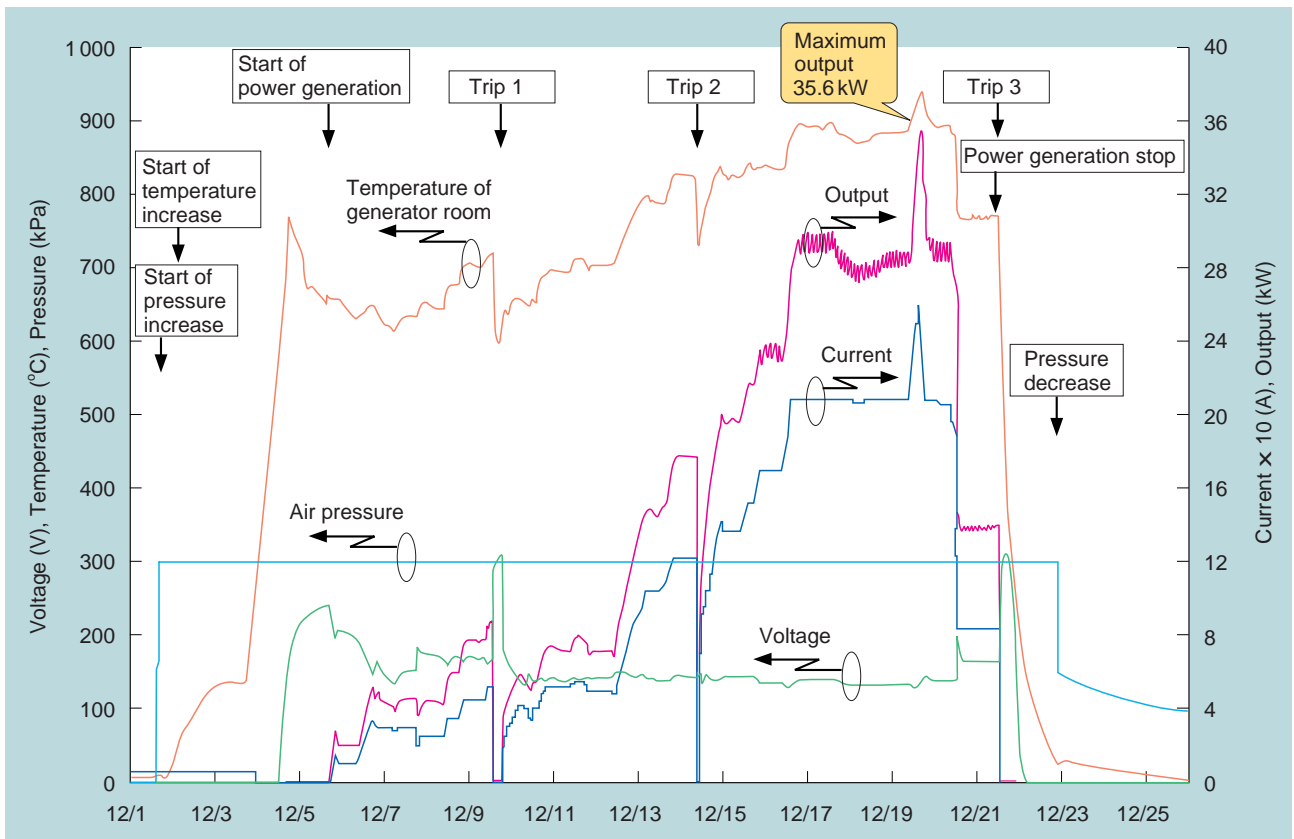

Fig. 5 Test operation result of pressurized module of 40kW class
 Maximum output in Japan of 35.6 kW (at that time) confirmed in operation under pressure.

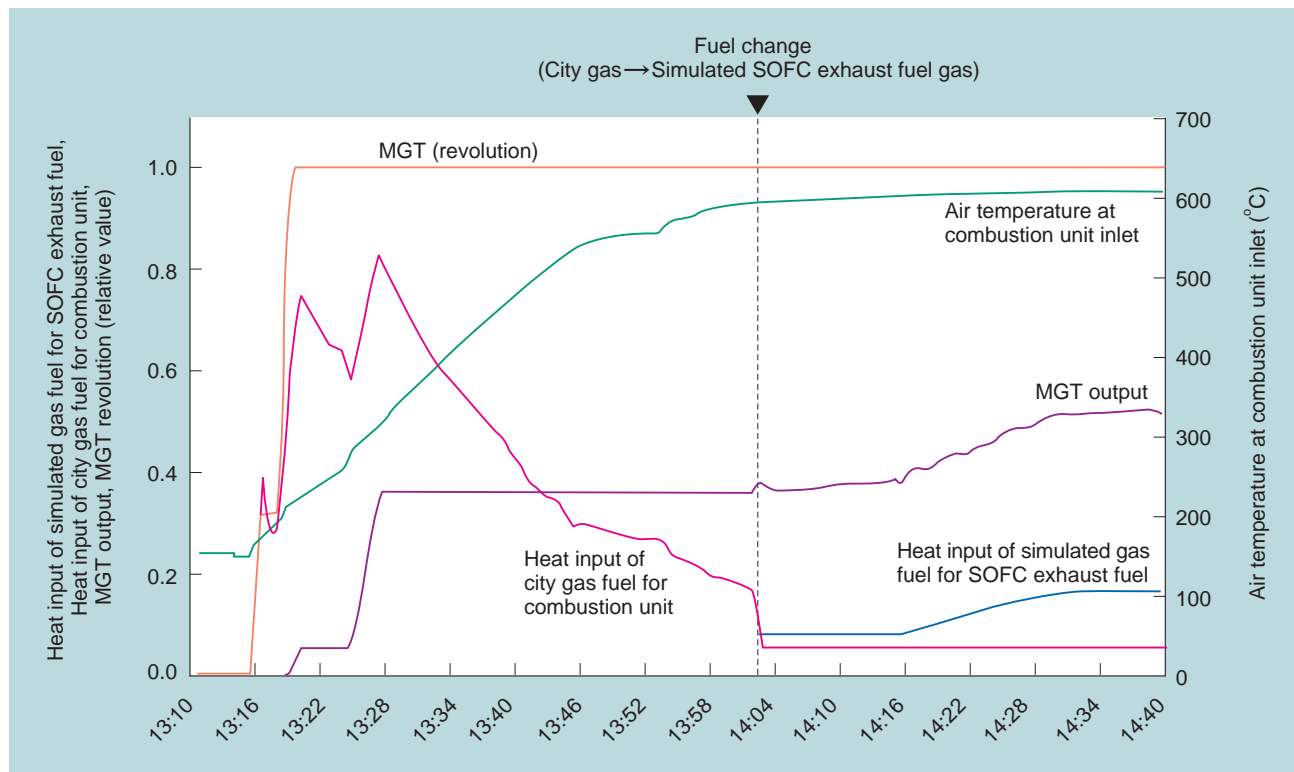

Fig. 6 Result of operation tests with low-calorific fuel firing micro gas turbine
 Stable operation with low-calorific fuel was confirmed.

3.4 Operation test of SOFC-MGT combined cycle system

By connecting the SOFC 40 kW class module used in the single-unit test in 2005 and the micro gas turbine fitted with the low-calorific gas combustion unit, we conducted verification tests of the combined operation in July 2006 and produced Japan's first SOFC-gas turbine combined cycle system. A photograph of the SOFC module and the trend of the combined operation verification tests are shown in **Figures 7 and 8**, respectively.

In the verification operation, the micro gas turbine was first started by use of city gas and the gas turbine generator was put into parallel operation within the system. Subsequently, air from the micro gas turbine was supplied to the SOFC and, after the SOFC temperature had increased, SOFC power generation was started and fed into the system. Because the SOFC exhaust fuel was fed into the micro gas turbine, a combined cycle power generation operation was achieved.



Fig. 7 40 kW class SOFC module
The first successful operation in Japan of SOFC gas turbine combined cycle system

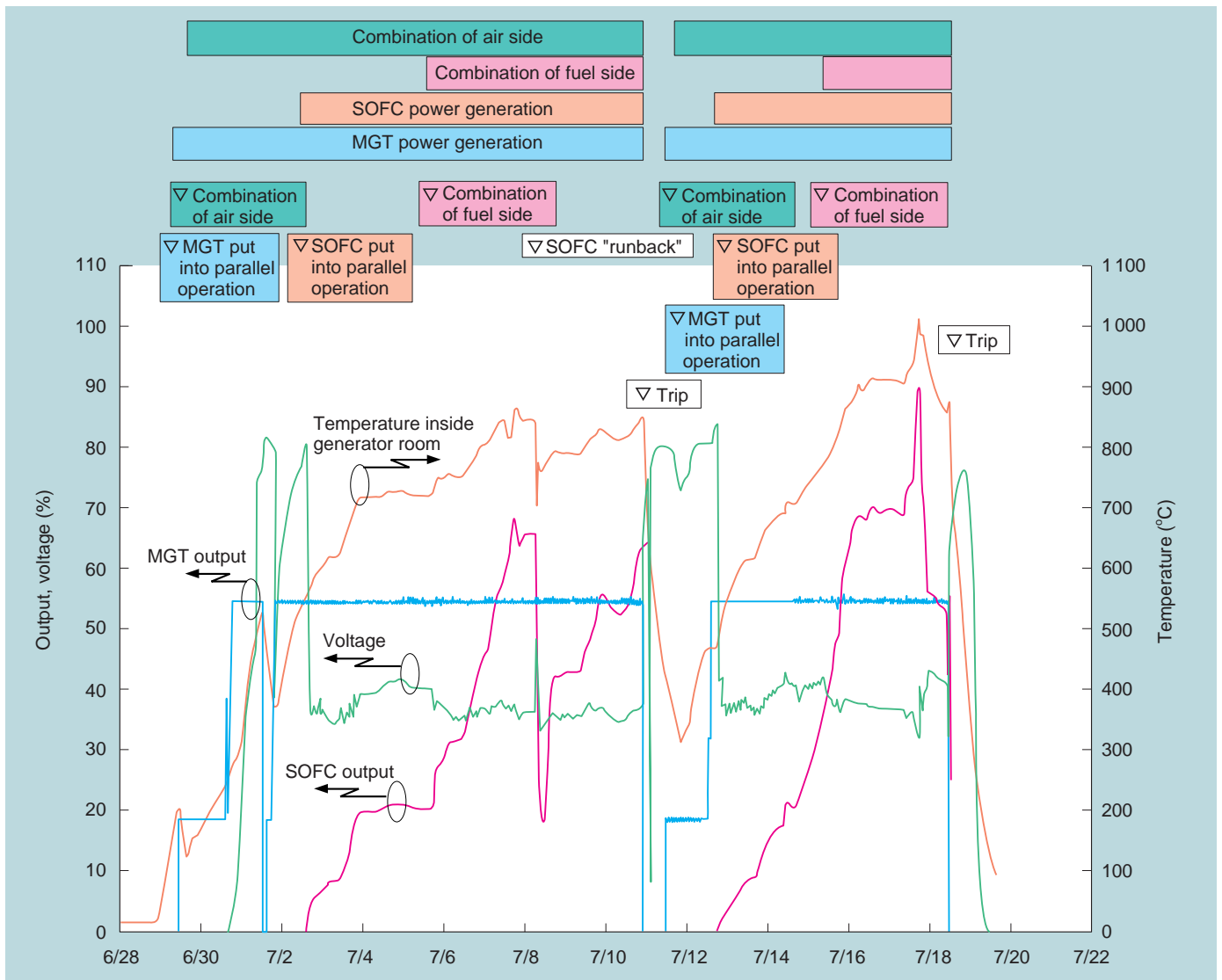

Fig. 8 Verification test result of SOFC micro gas turbine combined operation test
Stable power generation was carried out in combined cycle system operation mode. A combined cycle power output of 75 kW maximum was confirmed.

This verification operation confirmed stable power generation in combined cycle system with a maximum 75 kW output. It was also confirmed that the parallel control system, such as SOFC differential pressure control, operated as planned and the micro gas turbine operated stably during startup/steady/shutdown operations, startup operations of air supply to the SOFC, and transient states such as the micro gas turbine operation shifting to SOFC exhaust fuel and tripping operations.

3.5 200 kW class combined cycle system plan

Based on the results obtained so far regarding the development of the elements and control technology, we will continue working on designing and manufacturing the 200 kW class combined cycle system (first photo) whose operation is scheduled to start in 2007. The target performance for the 200 kW class combined cycle system is a power generation efficiency of above 50% (on the basis of city gas fuel LHV).



Tadashi Gengo



Yoshinori Kobayashi



Nagao Hisatome



Tatsuo Kabata



Yoshimasa Ando



Kenichiro Kosaka

4. Conclusion

High-efficiency power generation as a special feature of SOFC can be best utilized in a combined SOFC gas turbine-steam turbine power generation system. High-efficiency power generation will be 70% LHV or above when natural gas is used and 60% or above when coal gas is used. We expect to develop the technologies needed for both system development and elemental development of the SOFC micro gas turbine combined cycle system, thus contributing, by marketing the product, to a society using environmentally-friendly energy in the 21st century.

Acknowledgements

This paper includes the research plans and results of the "Development of a tubular type SOFC high efficiency combined cycle system" which was NEDO sponsored research. We would like to express our gratitude to all concerned parties.