



A Commencement of Commercial Operation at "MYSTIC COMBINED CYCLE PLANT" as a First Unit of M501G Combined Cycle in United States

HIDEO MATSUDA*1
TAKUYA NAITO*1

JUN YASURAOKA*1
SHINICHI HORI*1
KOICHI SHINDO*2

From 2003 through 2004, our newest combined cycle plants, which applied "1500°C-class M501G gas turbine" started commercial operation in various region of United States. These plants are characterized not only by the achievement of high thermal plant efficiency with unique steam-cooled combustion systems, utilizing cooling steam from HRSG, but also lower air emissions, strictly limited by environmental standard and regulations. In this thesis, the "MYSTIC COMBINED CYCLE PLANT", which became the first Mitsubishi M501G unit in United States, is mainly introduced.

1. Introduction

Mitsubishi Heavy Industries, Ltd. (MHI) had no experience supplying heavy-duty gas turbine to the United States market until 1999, however, seized opportunity to get an order for "1 600 MW MYSTIC Power Plant (Boston, MA)" as the first unit in the US, together with the "800 MW Fore River Power Plant." With a foothold on these experiences, other orders were also attained in Michigan and Texas (Fig.1). The M501G gas turbine machine with steam-cooled combustor cooling system is one of the features of these combined cycle plants, which makes it possible to get higher plant thermal efficiency than other existing power plants. In addition, they also achieve high reliability in compliance with strict stack emission limits required by environmental standards. These features are considered quite suitable for an advanced area of IPP dealings, especially for the US market.

From 2003 to 2004, four plants commenced commercial operation after the completion of the performance test and emission tests. A summary of these plants is shown in Table 1.

2. Outline of Mystic Power Plant

The MYSTIC POWER PLANT located in an industrial area just north of Boston, MA., and comprised of Block 8 and Block 9, the owner of the plant is Boston Generating, Co. (See Photo at the top of this page). The EPC portion was given to Washington Group International (previously Raytheon E&C). MHI supplied the gas turbines, steam turbines, HRSG (procured inside U.S.) and GT/ST control system.

In the area of the plant, there is also an existing conventional-type power plant (Block 7) next to Block 8 and Block 9. (See Photo at the top of this page; Block 7 on the left.) During start up period, in order to supply necessary cooling steam to gas turbine combustors, auxiliary steam is lead from this existing block to Block 8 and/or Block 9, or supplied between Block 8 and Block 9 each other.



Fig. 1 Locations of M501G combined cycle plant in USA
Figure in the bracket indicates the number of provided M501G gas turbine.

The cooling system of the plant is of an air-cooled type; an air cooled condenser comprised of 36 cells (partially equipped with VVVF fans) is provided for each block. An evaporative cooler as the gas turbine inlet air cooling system and supplemental duct firing system are provided in order to fulfill incremental power demand in summer season. These systems enable relatively over 9 percent of power increment corresponding to plant base load condition at 90°F of ambient temperature with 60% of relative air humidity.

In this region in Boston, very strict emission limits at stack outlet are required. For the MYSTIC power plant, the NOx emission limit is less than 2 ppm corrected to 15% O₂ dry volume basis, and CO emission limit is 2 ppm as well. Due to this fact, the solution was to apply Selective Catalytic Reduction (SCR) system and CO converting system, specially designed for this project in addition to the natural gas-fired Dry Low NOx (DLN) combustor.

*1 Power Systems Headquarters
*2 Takasago Machinery Works

Table 1 List of plants

Name of Plant	MYSTIC Block 8 & 9	FORE RIVER Block 1	WOLF HOLLOW	COVERT Unit 1, 2, 3
Location	Boston, Massachusetts	On suburbs of Boston, Massachusetts	On suburbs of Dallas, Texas	Southwest region of Michigan
Form of Contract	FOB + SV	FOB + SV	FOB + SV	FOB + SV
Form of Project	IPP	IPP	IPP	IPP
Owner	Boston Generating Co.	Boston Generating Co.	AES Corporation	National Energy & Gas Transmission, Inc. (NEGT)
EPC	WGI (Raytheon)	WGI (Raytheon)	Stone & Webster (Shaw)	Stone & Webster (Shaw)
Start of commercial operation	2003/4 and 2003/6	2003/7	Undisclosed	2004/1
Configuration	2-on-1 x 2 blocks	2-on-1 x 1 block	2-on-1 x 1 block	1-on-1 x 3 blocks
Plant Capacity	Approx. 1 600 MW	Approx. 800 MW	Approx. 730 MW	Approx. 1 100 MW
Inlet air cooling system	Evaporative cooler	Evaporative cooler	Evaporative cooler	Evaporative cooler
De-icing system	Provided	Provided	Provided	Provided
Supplemental firing system	Provided	Provided	Provided	Provided
Gas turbine	M501G (indoor)	M501G (indoor)	M501G (outdoor)	M501G (indoor)
HRSG	Triple pressure, Horizontal (indoor)	Triple pressure, Horizontal (indoor)	Triple pressure, Horizontal (outdoor)	Triple pressure, Horizontal (outdoor)
Steam turbine	Tandem-compound double flow (indoor)	Tandem-compound double flow (indoor)	Tandem-compound double flow (outdoor)	Single reheat axial flow (indoor)
Generator (gas turbine)	H ₂ -cooled type, Thyristor starting	H ₂ -cooled type, Thyristor starting	H ₂ -cooled type, Thyristor starting	H ₂ -cooled type, Thyristor starting
Generator (steam turbine)	H ₂ -cooled type	H ₂ -cooled type	H ₂ -cooled type	Air-cooled type
Condenser	ACC	ACC	Wet cooling tower	Wet cooling tower
Stack emission limits (corrected to 15%O ₂)	NO _x 2 ppmvd Ammonia 2 ppmvd CO 2 ppmvd	(N.gas / D.oil) NO _x 2 / 6 ppmvd Ammonia 2 / 2 ppmvd CO 2 / 7 ppmvd	NO _x 9 ppmvd Ammonia 10 ppmvd CO 25 ppmvd	NO _x 2.5 ppmvd Ammonia 10 ppmvd CO 5 ppmvd
Type of Fuel	Natural gas single	Natural gas / D. oil (Dual)	Natural gas single	Natural gas single

IPP: Independent Power Producer

EPC: Engineering Procedure and Construction

HRSG: Heat Recover Stream Generator

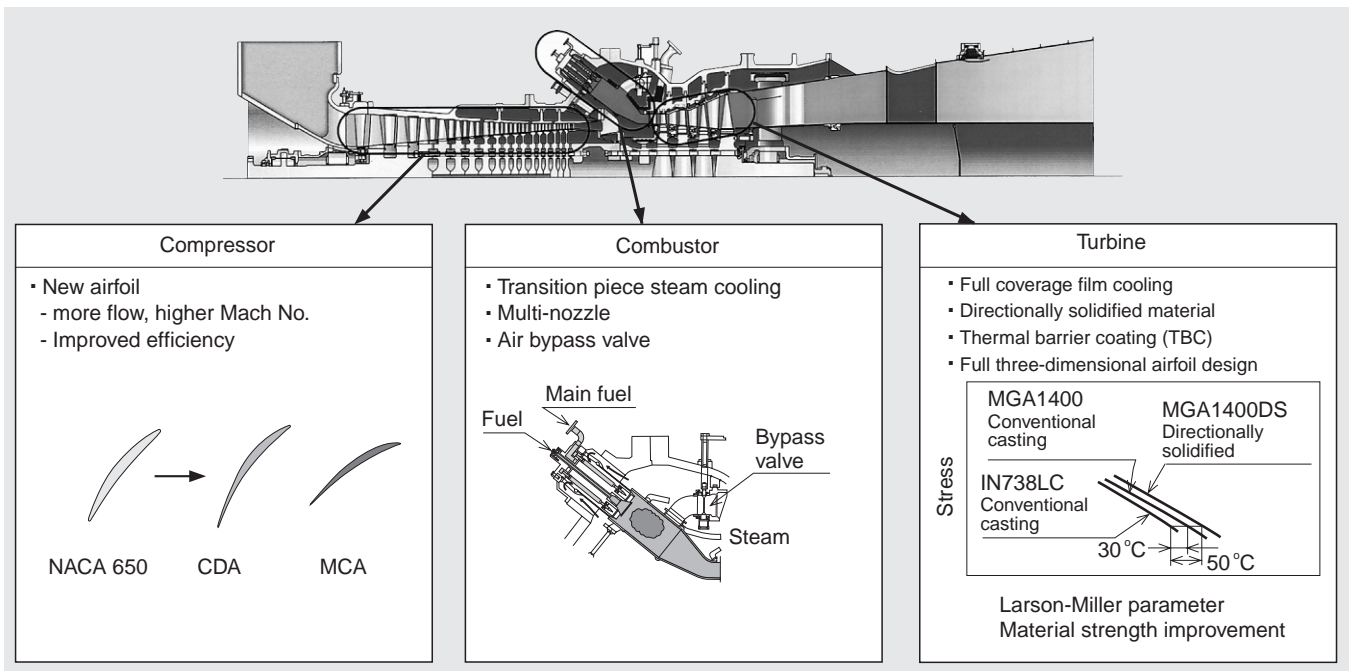

Fig. 2 Advanced technology applied to G-series gas turbine

3. M501G gas turbine technology

The M501G Gas Turbine has long operational experience and has maintained high reliability since 1997. It was the world's first closed-cycle steam cooling application to cool the combustor.

The latest 17th-stage axial flow type compressor was newly designed for the G series gas turbine. MCA (Multiple Circular Arc) blades were employed to attain a large volume, high efficiency, low aerodynamic loss and higher pressure ratio. These latest airfoils display excellent performance in the high Mach number range. CDA (Controlled Diffusion Airfoil) for other cascade were also applied to prevent the boundary layer from growing.

The combustor is an extrapolation of the successful day low NOx combustor developed for the F type gas turbine. One pilot and 8 main nozzles around pilot nozzle were equipped, Pre-mixed flame could keep stable condition by the diffusion flame of the pilot.

In order to attain the same NOx value as that of the F series gas turbine in the 1500°C class gas turbine, it is necessary to control the gas temperature in the combustion region within a range of 1500 to 1600°C, same as the F series gas turbine. Furthermore, it was decided to employ the closed type steam cooling system in the G series gas turbine of these projects in order to restrain the cooling air for the combustor. The steam heat obtained from the combustor contributes to improvement of plant thermal efficiency by recovering at the bottoming cycle. Its performance and reliability were verified by the atmospheric-pressure combustion test, high-pressure combustion test and actual plant other than US area.

This turbine is a high load and high-efficiency turbine of the axial flow type with four stages capable of dealing with increases in load due to an increase in the turbine inlet temperature. A fully three-direction is employed with the aim of reducing secondary loss generated near the airfoil and end wall.

An air cooled airfoil is employed for the blades and vanes from 1st to 3rd. For 1st vane, addition to the cooling system of impingement, heat input was reduced by the full coverage film cooling to cover vane whole surface. Thermal barrier coating (TBC) was also applied on vane surface and shroud to minimize the heat effect. For the 1st blade serpentine cooling system with angled turbulator and full coverage film cooling same as 1st vane were employed to improve cooling performance.

For 2nd and 3rd, the same cooling technology was applied and it contributes to high performance of gas turbine. Besides that, 1st and 2nd blade adopts directionally solidified material to improve hot parts life.

Such advanced technologies keep the G series performance and reliability high. (Fig.2)

4. Heat Recovery Steam Generator (HRSG)

The HRSGs are horizontal, triple pressure reheat type, procured inside United States and provided by Deltak, LLC. As stated above, the limit of emission requirement is extremely severe therefore SCR and CO converter are installed inside the HRSG. As for SCR, since the requirement of ammonia slip concentration limit is the same degree as that of NOx (2 ppm), special design was taken into account as summarized below.

- Porous panel was arranged at the inlet of HRSG in order to obtain uniform gas velocity
- Widen exhaust gas flow area at the part of SCR section in order to reduce exhaust gas velocity
- Mixer was installed downstream of the ammonia injection nozzle for the promotion of mixing ammonia with exhaust gas uniformly
- The location of SCR was optimized with a consideration of the exhaust gas temperature based on various parameters which affect the SCR efficiency, such as duct burner location, capacity and gas turbine operational load range.

In accordance with the above design philosophy, the HRSG achieved superior performance, especially in terms of environmental protection.

5. Steam turbine technology

The steam turbine consists of one (1) combined high-pressure/intermediate-pressure (HIP) turbine and one (1) low-pressure (LP) turbine.

The HP dummy ring is integrated onto the nozzle box or inner casing to realize the HIP outer casing compact design.

HP second, third, and fourth stationary blades are supported by the inner casing, and cooling steam is circulated in the space between inner casing and outer casing to reduce the design pressure and temperature of outer casing. Also, additional cooling steam is introduced into the flange of the outer casing. By applying this feature, low Cr steel without vanadium has been able to be adopted as the outer casing material.

The stationary blades are of the combined type, which are supported directly by the outer casing, as a result blade ring construction is not required. This construction has the advantage of controlling the unsteady clearance and re-

ducing the total weight of stationary parts. To reduce the leakage steam flow through the clearance between inner ring and rotor, stationary blade inner seal diameter is decreased.

Also to reduce the leakage steam flow at dummy piston, the dummy piston diameter is decreased by adopting the total thrust balance design. The total thrust balance design is accomplished by considering the pressure scattering in actual operation, and changing of the seal clearance, etc. The direct lubricating thrust bearing, of which mechanical loss is remarkably less and thrust endurance is larger than usual leveling plate type, is applied. Before applying this thrust bearing, we verified its unstable load limit in our test machine, and also measured some existing turbine actual thrust force comparing with their design force. Moreover, ACC (Active Clearance Control) is adopted at the dummy piston in order to reduce leakage steam flow during high load operation by decreasing the radial clearance.

For LP-END blade, 40" high performance steel blade is adopted to realize low-cost and excellent performance. LP exhaust flow guide is designed according to the result of CFD and the number of reinforce rib is selected as per CFD results. By applying this technology, compact flow chamber is realized.

LP turbine bearing is directly supported on the foundation in order to improve the shaft-system vibration characteristic. The LP gland ring is supported on the bearing pedestal and LP turbine inner casing is directly supported on the foundation. This construction maintains uniform clearance against vacuum load and the rubbing between rotating parts and stationary parts can be avoided.

By applying the above mentioned technologies, a high performance and compact steam turbine is realized (Fig.3).

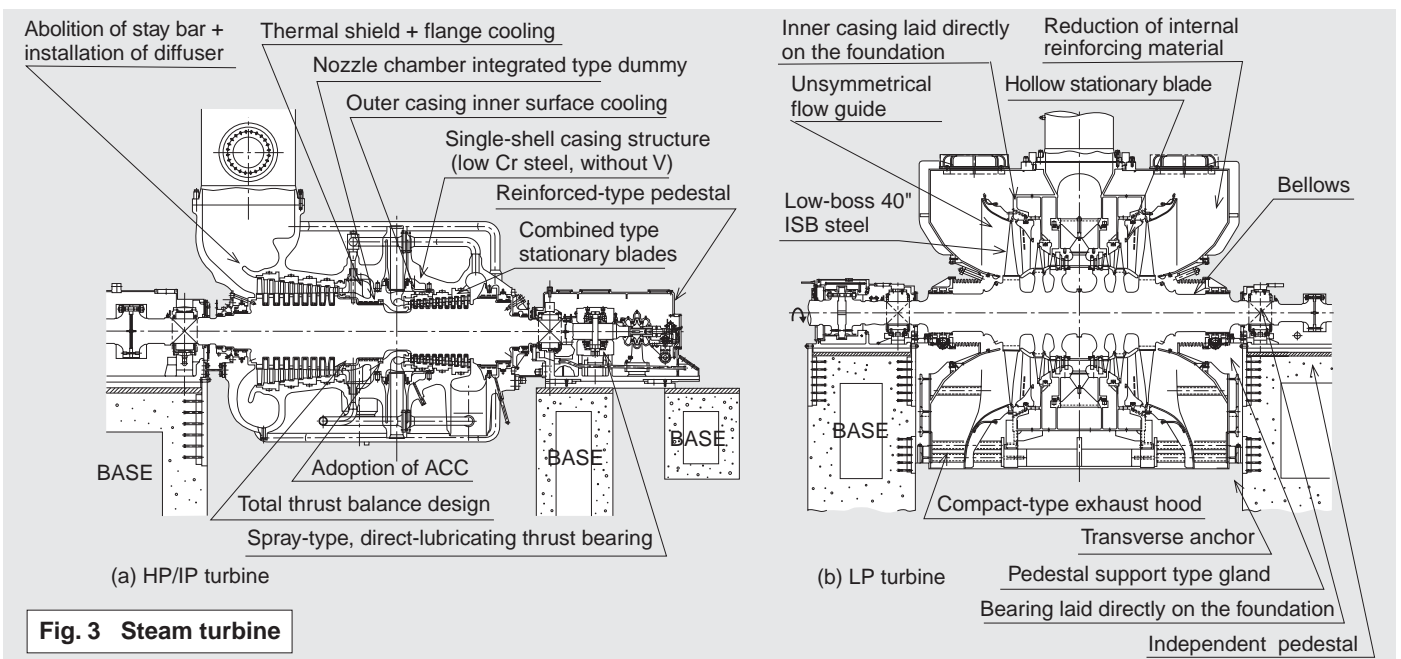

Fig. 3 Steam turbine

6. Construction and commissioning schedule

With regard to construction and commissioning schedule, our company was in a position of dispatching Technical Advisers (TA) for own equipment. The commissioning progressed without major trouble and was handed over to the customer.

(1) Records of Mystic Block 8 commissioning

- Ignition of gas turbine #81: Beginning of Sep, 2002
- Ignition of gas turbine #82: Beginning of Nov, 2002
- Steam admission into steam turbine #85: Beginning of Dec, 2002
- Block 8 100% load attainment: End of Dec, 2002
- Block 8 Adjustment of SCR system, continuous emission monitoring test and 10 days reliability test run: Feb, 2003
- Block 8 Performance acceptance test: Beginning of Apr, 2003

(2) Records of Mystic Block 9 commissioning

- First Ignition of gas turbine #93: Beginning of Mar, 2003
- First Ignition of gas turbine #94: Beginning of Apr, 2003
- Steam admission into steam turbine #96: End of Apr, 2003
- Block 9 100% load attainment: Middle of May, 2003
- Block 9 Adjustment of SCR system, continuous emission monitoring test and 10 days reliability test run: May, 2003
- Block 9 Performance acceptance test: End of May, 2003

7. A brief introduction of other M501G based plant in U.S. market

In addition, our company constructed three combined cycle plants in the U.S. They also started commercial operation successfully.

The Fore River Plant is a plant provided to the Boston Generating Company as well as the Mystic plant. The specification and site location are similar to the Mystic plant except for using dual firing system as a back up fuel.

The Wolf Hollow Plant locates on the suburbs of Dallas, TX. Major equipment such as gas turbines, HRSGs, Steam Turbines of this plant is of the outdoor type. Other specifications are also similar to Mystic plant. In this region, no CO catalyst is provided since air emission regulation requirement in this area is not as severe compared with other areas.

The Covert Plant is provided to NEGTEC Inc., located in the southwest area of Michigan. Different from other plants, this plant is comprised of three blocks, each with multi-shaft 1 on 1. The steam turbine is axial flow with single casing reheat type. The NOx emission limit is comparatively severe and its requirement is 2.5 ppm (corrected to 15%O₂). In the meantime, ammonia slip from stack is allowed up to 10 ppm, therefore no special design is considered into HRSG and SCR as Mystic/Fore River.

8. Conclusion

The outline of features and corresponding technology of the M501G combined cycle plant, started commercial operation in USA from 2003 through 2004, principally for the first unit of Mystic combined cycle plant, was introduced in this paper. It is generally understood that further improvement of thermal performance and also reduction of air emissions are required in US market. MHI intends to make efforts in technical developments based on the experiences obtained in the aforementioned M501G based combined cycle plants.



Hideo Matsuda



Jun Yasuraoka



Takuya Naito



Shinichi Hori



Koichi Shindo