

Development of Small Size, Light Weight and High Power IPM Motor for Electric Vehicle

AKIRA NISHIO*1
 MASAHIRO HIRANO*1
 YOSHIKI KATO*1
 TAKAYUKI IRIE*2
 TSUTOMU BABA*3

Mitsubishi Heavy Industries, Ltd (MHI) has recently developed small-size, light-weight and high-power IPM motor and inverter for electric vehicles. This paper describes the system configuration of the electric vehicle and hybrid vehicle and the technologies used for the small-size, light-weight and high-power IPM motor and inverter developed by MHI for electric vehicles. With the skillful arrangement of permanent magnets, optimized combination of rotor poles/stator slots, adoption of concentrated winding, etc., the motor is designed to ensure high current density, high torque constant and high power factor in order to realize high power, approximately 2.5 times higher, in terms of power/volume ratio, than the conventional motor. Realization of small size and light weight has also been achieved in inverter through optimization of water-cooling structure and by integrating the power circuit and the control circuit in one board.

1. Introduction

Because of the environmental problems such as exhaustion of natural resources, increase in the emission of carbon dioxide, etc., developments are being actively carried out recently in electric vehicles (EV), hybrid electric vehicles (HEV) and fuel cell electric vehicles (FCEV). Motors for driving these vehicles are demanded to be smaller in size, lighter in weight and higher in power in order to improve fuel consumption and to ensure larger space inside the vehicles. There is particularly a high demand for high power and high efficiency from the low-speed rotation zone (region) through the high-speed rotation zone.

With the rare earth magnet having its performance improved and cost reduced in recent years, attention has

been drawn to the IPM (Interior Permanent Magnet) motor suitable for high-speed rotation and capable of being made smaller in size, lighter in weight and higher in efficiency than the induction motor.

MHI has recently developed small-size, light-weight and high-power IPM motor and inverter for electric vehicle by making an effective use of its long amassed technologies for the development of the conventional servo-motor and amplifier. This paper describes the system configuration of electric vehicle and hybrid electric vehicle, the technologies used for small-size, light-weight and high-power IPM motor and inverter developed by MHI for electric vehicles, and the product specifications.

2. Outline of System Configuration

Fig. 1 shows the system configuration of electric ve-

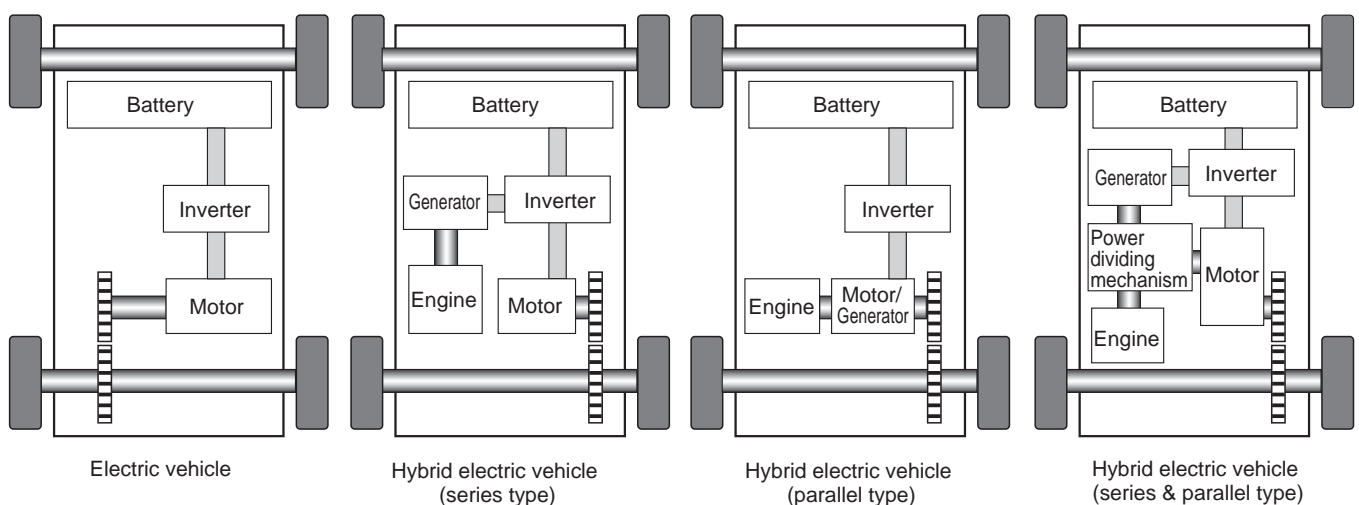

Fig. 1 System configuration of electric vehicle and hybrid electric vehicle

The electric vehicle and hybrid electric vehicle are classified mainly in 4 types of system.

*1 Kobe Shipyard & Machinery Works
 *2 Takasago Research & Development Center, Technical Headquarters
 *3 Seiryō Engineering

hicle and hybrid electric vehicle (series type, parallel type and series & parallel type)

The electric vehicle uses a motor as power source and operates only by the power from the battery. At the time of speed reduction (slowdown) or at downgrade hill drive, the motor works as a generator, regenerating power to the battery. The battery of this system is replaced with a fuel cell in the case of a fuel all electric vehicle.

The hybrid electric vehicle, on the other hand, uses two power sources: engine and motor. There are mainly three types of hybrid electric vehicle.

The series type uses the engine to operate the generator, and the generated power is used for driving the motor for traveling. In the case of parallel type, the engine plays main role for traveling. In some cases, the engine is used as a power source to charge the battery, therefore the motor gets activated and works as an auxiliary at the time of start or acceleration. The series & parallel type is a combination of series type and parallel type and uses both motor and generator, with motor being used for low-speed drive. At a speed above a certain level the engine starts operation, and keeps on traveling while generating power when the drive load gets light.

In the aforesaid system types the motor and inverter work as a substitute or an auxiliary for the engine, so that they are demanded to be smaller in size, lighter in weight and higher in efficiency in order to improve fuel consumption and to ensure low emission of exhaust gas.

The effect of improvement in fuel consumption of a hybrid electric vehicle is shown in Fig. 2⁽¹⁾, indicating that the higher the motor power, the larger the effect of improvement in fuel consumption. Since a hybrid electric vehicle needs both motor and engine, the installation place for motor and inverter is limited, so that small-size, light-weight and high-power motor and inverter are indispensable.

3. Technologies for Small Size, Light Weight and High Power

Fig. 3 shows an example of the newly developed motor and inverter for electric vehicle.

3-1 Motor

The motor for electric vehicle is required of the operation up to a high-speed zone (area). Hence, the conventional servo motor type surface permanent magnet motor (SPM motor) with the magnet pasted on the surface gives rise to a problem of the fly-off of the magnet due to the centrifugal force at high speed zone and demagnetization resistance because of field-weakening control. We have therefore adopted the IPM motor where the magnet is embedded inside. The IPM motor has an advantage that it can maintain high power up to the high speed zone by making use of field-weakening control.

In order to make a motor smaller in size, lighter in

weight and higher in power it is necessary to increase the energy density, the volume ratio to the output power of the motor. And in order to increase the motor energy density, the following three points must be taken into account.

(1) High current density

In case of a conventional IPM motor, excessive flow of current brings about magnetic saturation, leading to a drastic change in inductance. So, it was not possible to flow excessive current. Further, it has a characteristic of the inductance getting sharply increased when the current lead angle gets large at the time of field-weakening control (Fig. 4). As is obvious in equation (1), these characteristics cause the terminal voltage of the motor to increase at the time of high-speed rotation. Since there is an upper limit for the inverter output voltage in relation to the battery voltage, no more current can be flowed if the motor terminal voltage exceeds the said upper limit.

$$V_a = \sqrt{(R_a i_d - \omega L_q i_q)^2 + (R_a i_q + \omega L_d i_d + \omega \psi_a)^2} \quad (1)$$

where;

V_a : Motor terminal voltage [Vrms]

R_a : Motor winding resistance []

i_d, i_q : Current in d, q axes [A]

L_d, L_q : Inductance in d, q axes [H]

ω : Electrical angular velocity [rad/sec]

ψ_a : Armature flux linkage due to permanent magnet [Wb]

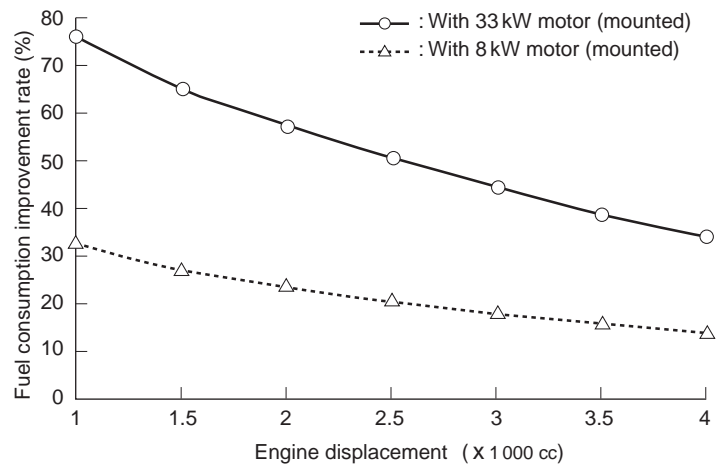

Fig. 2 Mileage/Liter⁽¹⁾

The higher the motor power, the greater the effect of improvement in fuel cost.

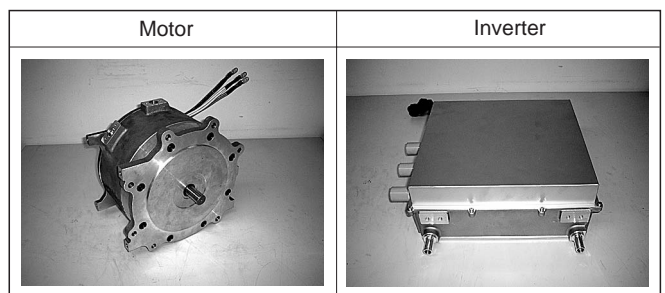

Fig. 3 Motor and inverter for electric vehicle

Shows the example of the motor and inverter developed for electric vehicle.

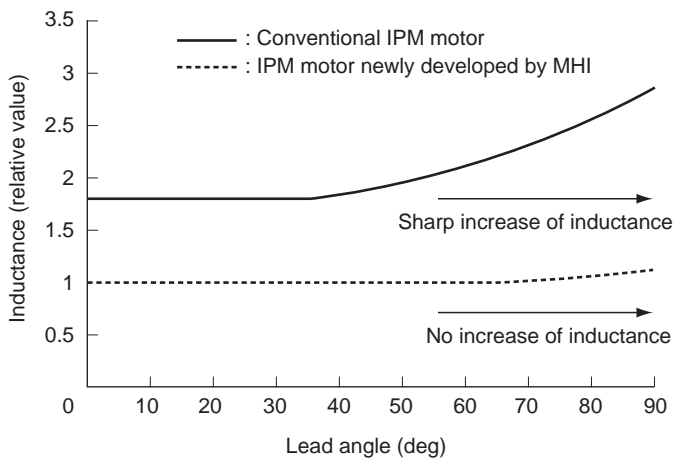

Fig. 4 Armature inductance vs. current lead angle
The MHI IPM motor has the armature inductance hardly increased even when the current lead angle gets increased.

In the case of MHI IPM motor, however, the magnet arrangement is carefully devised in order to reduce the inductance as well as to raise the limit of magnetic saturation. Further, the rise in motor terminal voltage is controlled by minimizing the change in inductance even when the current lead angle gets large at the time of field-weakening control in high-speed rotation zone, ensuring high current density.

(2) High torque constant

As is clear from equations (2) and (3), increasing the motor torque constant (armature flux linkage due to permanent magnet) to increase the energy density has conventionally been avoided since it results in high electro-motive force (e.m.f.). However, the active utilization of field-weakening control can increase the torque constant for realization of a high-power motor.

$$T = P_n \left\{ \psi_a i_q + (L_d - L_q) i_d i_q \right\} \quad (2)$$

$$\omega \psi_a = \sqrt{3} K_e * N \quad (3)$$

where;

T : Torque [Nm]

P_n : The number of motor pole pairs

K_e : Electro-motive force constant [Vrms/rpm]

N : Rotational speed [rpm]

With the rotor diameter, winding system and the other electrical characteristics being equivalent, it is necessary to increase the number of poles in order to increase the torque constant.

Further, with the stator diameter, thickness and number of poles being equivalent, the torque constant is proportional to the number of winding turns. In order to increase the number of winding turns, it is necessary to increase the cross-section of the slot, the winding groove,; and in case the number of slots is the same, the preliminary condition for the above will be the small cross-section of the tooth of 1 piece of slot. Taking the aforesaid factors into consideration, MHI carried out optimization of the combination of pole number and slot number.

In the case of a motor with optimized numbers of poles and slots, the winding factor against the fundamental magnetic flux can be brought closer to 1 by adjusting the opening width of the slot, and the winding factor against the high-frequency magnetic flux can also be reduced to ensure high torque constant.

MHI takes account of this fact, and has optimized the width of slot opening to ensure high torque.

(3) High power factor

In the case of a conventional IPM motor, the inductance in q-axis is large and the effect of armature reaction is also large, causing the power factor to get decreased when a large torque is generated. The MHI IPM motor, however, has the distance between the permanent magnet embedded in the rotor and the rotor surface optimized to reduce the q-axis inductance to ensure high power factor even when the generated torque is large.

Besides, MHI IPM motor has slot-saving winding system and adopts the concentrated winding that can be carried out using an automatic machine. Further, the motor has been made smaller in size by adopting water cooling system instead of the forced air cooling used in the conventional servo motor.

A comparison between the conventional servo motor and the newly developed IPM motor is shown in **Table 1**. By using the aforesaid technologies, the

Table 1 Comparison of motor main specification

No.	Item	Motor for electric vehicle (example)	Conventional servo motor
1	Rated power (kW)	40	22
2	Rated input current (Arms)	133	120
3	Maximum output power (kW)	75	47
4	Maximum input current (Arms)	340	310
5	Volume (m ³)	0.0141	0.0242
6	Weight (kg)	58	76
7	Cooling system	Water cooling	Forced air cooling
8	Structure	Waterproof specification	-

Table 2 Comparison of inverter main specification

No.	Item	Inverter for electric vehicle	Conventional servo motor
1	Rated output current (A _{rms})	133	138
2	Maximum output current (A _{rms})	340	345
3	Current control system	Sinusoidal PWM control	Sinusoidal PWM control
4	Input power (V)	DC 288	AC 200 – 220
5	Structure	Totally enclosed/Water cooling system	Forced air cooling
6	Weight (kg)	18	40
7	Volume (m ³)	0.01734	0.05337

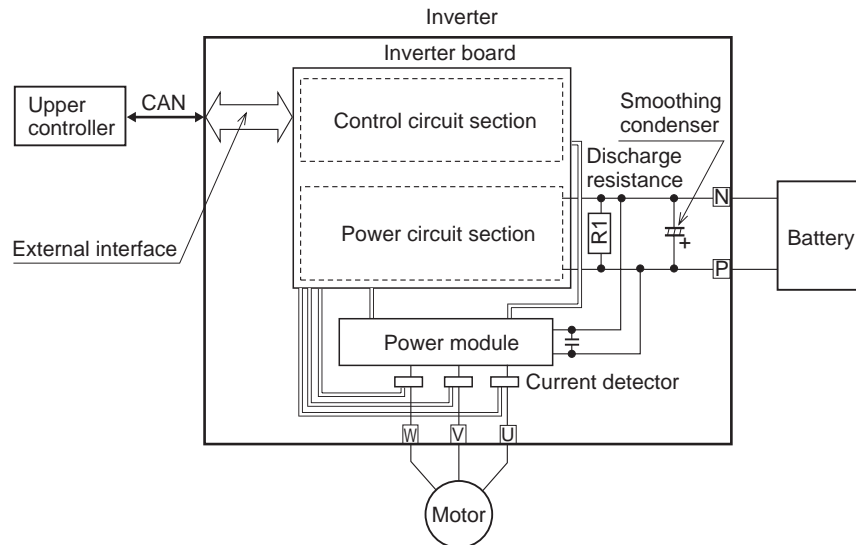

Fig. 5 Inverter system configuration
Adopts the international standard CAN for communication with upper controller.

power/volume ratio has been increased to 2.5 times larger than that of the conventional servo motor.

3-2 Inverter

The main specifications of the inverter for electric vehicle and the conventional servo amplifier are given in **Table 2** and the internal configuration of inverter in **Fig. 5**. The inverter largely differs from the conventional servo amplifier in (I) the adoption of CAN, the international standard for communication with upper controller and (II) the field-weakening control by means of current control.

The conventional servo amplifier uses forced air cooling system for cooling the power module, while the newly developed inverter uses water cooling in order to reduce the size. In addition, the water cooling system is designed to have optimized cooling fan to ensure small size and high efficiency.

Furthermore, the inverter is designed to totally enclosed and waterproof structure so as to be installed inside the engine room. In addition to this, the power and control circuits are integrated into one board for less wiring and small size to upgrade work efficiency at the time of assembly.

By using the aforesaid technologies, the volume could

be reduced to one-third and the weight to half as compared with the conventional servo amplifier with the same power (output).

4. Product Specifications

Specifications of motors so far developed for electric vehicle and hybrid electric vehicle are given in **Table 3**, indicating that the small size, light-weight and high-power motor and inverter have been realized by using the technologies for small size, light weight and high power mentioned in Section 3.

The rotational frequency (speed) vs. torque and power characteristics of Type 3 motor applied to parallel hybrid system is shown in **Fig. 6**, while the system configuration of the hybrid electric vehicle using this motor in **Fig. 7**. In this system, the battery voltage is 42 V and the motor has three functions working as a starter, generator and auxiliary driving force at the time of start and acceleration. The use of MHI small-size, light-weight and high-power motor and inverter has been verified to improve the fuel consumption by 40%.

5. Conclusion

We have so far described the technologies for small-

Table 3 Specification of Motor for conventional (already developed) electric vehicle and hybrid electric vehicle

Item	Type-1	Type-2	Type-3	Type-4
Maximum output power (kW)	100	33	13	35
Maximum torque (Nm)	250	82	90	197
Maximum rotational speed (rpm)	5 750	6 000	6 000	3 750
Case diameter/stator diameter*1 (mm)	320	280	238	330
Case length/stator length*1 (mm)	290	189	35	60
Cooling system	Water cooling system	Water cooling system	Water cooling system	Water cooling system
Power voltage (V)	380	240	42	288
Applicable vehicle type	Electric vehicle	Hybrid	Parallel hybrid	Parallel hybrid
Type*2	Motor type	Motor type	Build-in type	Build-in type

*1: Indicates case diameter and case length in the case of motor type and stator diameter and stator length in the case of build-in type.

*2: Motor type indicates normal motor case type, while build-in type indicates the type installed to the engine case.

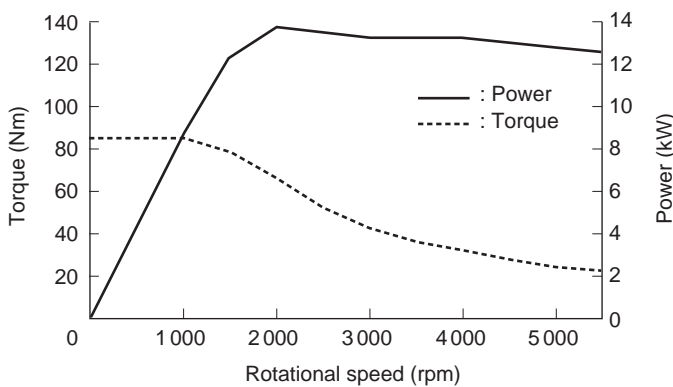

Fig. 6 Speed vs. torque and power characteristics (Type-3)
Indicates the high power maintained over the high-speed zone.

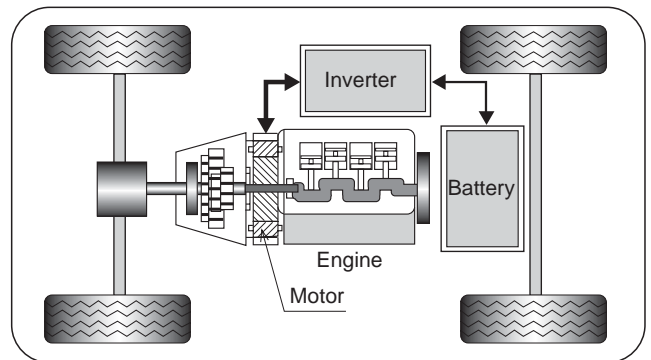

Fig. 7 System of hybrid electric vehicle using Type-3 motor
Battery voltage is 42V, and the motor carries out functions of starter, generator and auxiliary to driving force at start and acceleration.

size, light-weight and high-power motor and inverter developed by MHI for electric vehicles. The newly developed motor has realized a power about 2.5 times as large as that of a conventional servo motor of equivalent volume through skillful arrangement of permanent magnet, optimization of rotor pole number/stator slot number, adoption of concentrated winding, etc. Further, the inverter has realized a volume as large as one-third of a conventional servo amplifier of equivalent power through water-cooling structure and integration of control and power circuits in one board.

Furthermore, these technologies were used in the motor and inverter for hybrid electric vehicle system, and have been found to be substantially effective for improving the fuel consumption.

We are determined to carry on our development mission to produce the motor and inverter smaller in size, lighter in weight and higher in power, to improve reliability of our products and to widen the applicable vehicle types.

Reference

- (1) The Relation between Motor Generator Output Power and Fuel Consumption Improvement, and Manufacture's Catalog Data, D & M Nikkei Mechanical, Nikkei BP No.573 (2002) p.81



Akira Nishio



Masahiro Hirano

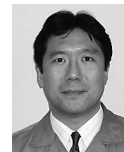

Yoshiki Kato



Takayuki Irie



Tsutomu Baba